

SECTION E

THE CLUTCH

Description of the Clutch Assembly.

Section No. E.1	Running adjustments.
Section No. E.2	Removing the clutch.
Section No. E.3	Dismantling the clutch.
Section No. E.4	Assembling the clutch.
Section No. E.5	Refitting the clutch.
Section No. E.6	Adjusting the release levers.
Section No. E.7	Refacing the driven plate.
Section No. E.8	Servicing the clutch.
Section No. E.9	The universal clutch gauging fixture.
Section No. E.10	Fitting a rubber buffer to the clutch cross-shaft.

GENERAL DESCRIPTION

The clutch is of the single-plate dry-disc type, no adjustment for wear being provided in the clutch itself. Individual adjustment is provided for locating each lever during initial assembly. The adjusting nuts are locked in place and should never be disturbed unless the clutch is dismantled for the replacement of parts.

The general construction can be followed by reference to Fig. E.1 and the following description :—

The driven plate assembly

This consists of a splined hub and flexible steel driven plate (3), to the outer diameter of which are fixed the annular friction facings. This plate is attached to the splined hub by a spring mounting which provides a torsional cushion.

The release bearing assembly

This comprises the graphite release bearing (7) mounted in a cup attached to the operating fork, and a release plate (10) is attached to the inner ends of the release levers (12) by means of the retainer springs (11). Release is accomplished by moving the release bearing forward into contact with the release plate and thus applying pressure to the release levers.

Cover assembly

Each release lever is pivoted on a floating pin (16) which remains stationary in the lever and rolls across

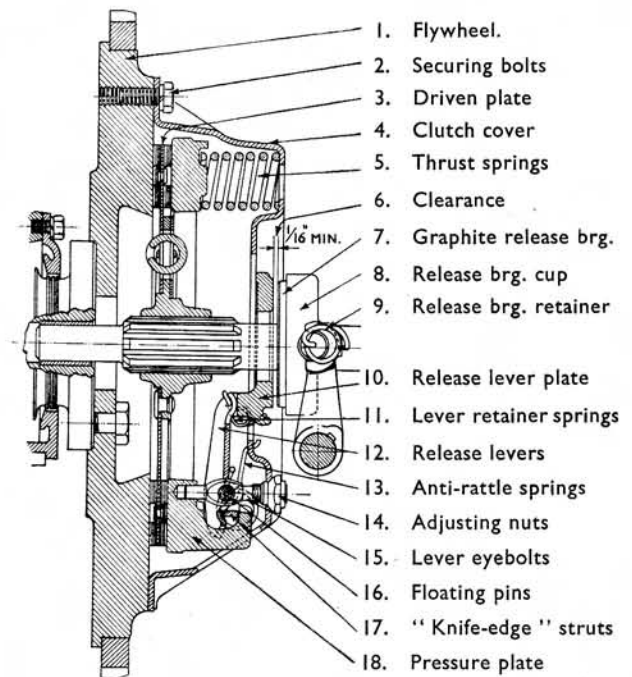
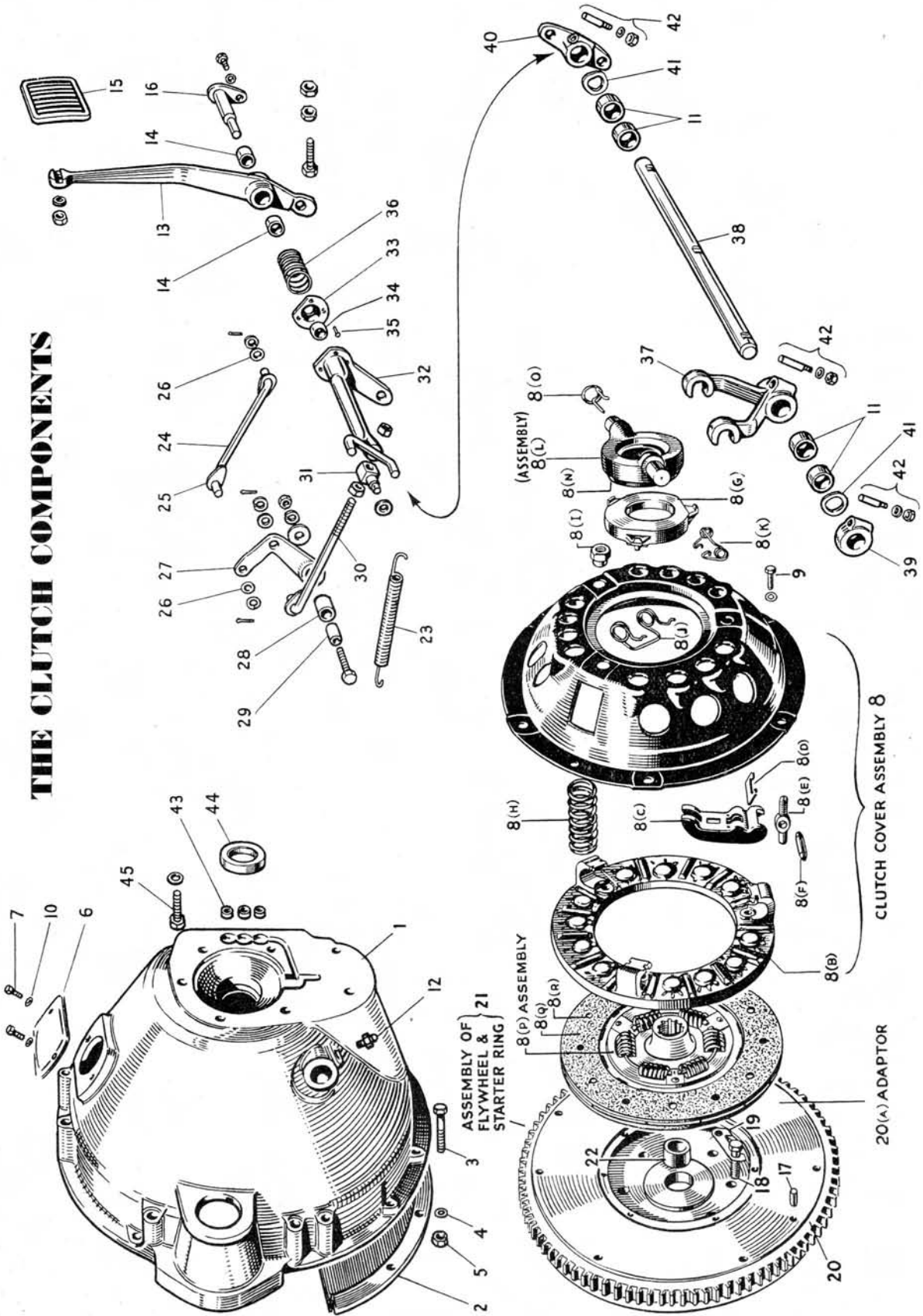

Fig. E.1.
Section through the clutch.

a short flat portion of the enlarged hole in the eyebolts (15). The outer ends of the eyebolts extend through holes in the clutch cover and are fitted with adjusting nuts (14) by means of which each lever is located in its correct position. The outer or shorter ends of the release levers engage the pressure plate

THE CLUTCH COMPONENTS



KEY TO THE CLUTCH COMPONENTS

No.	Description	No.	Description	No.	Description
1.	Housing—clutch.	8(P)	Plate assembly—clutch driven.	26.	Washer—clutch intermediate rod.
2.	Shield—clutch housing.	8(Q)	Facing package—clutch driven plate.	27.	Lever assembly—clutch intermediate.
3.	Bolt—clutch housing shield.	8(R)	Rivet—clutch driven plate facing.	28.	Bush—clutch intermediate lever.
4.	Washer—spring—clutch housing shield.	9.	Bolt—clutch to flywheel.	29.	Collar—pivot—clutch intermediate lever.
5.	Nut—clutch housing shield.	10.	Washer—spring—clutch inspection cover.	30.	Rod assembly—clutch.
6.	Cover—clutch inspection.	11.	Bush—clutch housing.	31.	Trunnion.
7.	Screw—clutch inspection cover.	12.	Greaser—clutch housing.	32.	Shaft assembly—clutch cross.
8.	Cover assembly—clutch.	13.	Pedal assembly—clutch.	33.	Housing bush—clutch cross-shaft.
8(B)	Plate—clutch pressure.	14.	Bush—clutch pedal.	34.	Bush—clutch cross-shaft.
8(C)	Lever—release—clutch.	15.	Pad—clutch pedal—complete.	35.	Rivet—bush housing.
8(D)	Strut—clutch release lever.	16.	Pin—clutch pedal fulcrum.	36.	Spring—clutch cross-shaft.
8(E)	Eyebolt—clutch release lever.	17.	Dowel—flywheel to clutch.	37.	Fork—clutch operating.
8(F)	Pin—clutch release lever.	18.	Bolt—flywheel.	38.	Shaft—clutch operating fork.
8(G)	Plate—release lever.	19.	Lockstrip—flywheel bolt.	39.	Collar—clutch operating fork.
8(H)	Spring—clutch thrust.	20.	Ring only—starter.	40.	Lever—clutch operating.
8(I)	Nut—eyebolt.	20(A)	Adaptor—flywheel.	41.	Washer—clutch operating.
8(J)	Spring—anti-rattle—clutch lever.	21.	Flywheel and starter ring.	42.	Cotter—fork, shaft and lever.
8(K)	Retainer—release lever plate.	22.	Bush—flywheel.	43.	Seal—shifter shaft oil.
8(L)	Bearing and cup assembly—clutch release.	23.	Spring—clutch pedal pull-off.	44.	Seal—drive gear oil.
8(N)	Bearing only.	24.	Rod assembly—clutch intermediate.	45.	Bolt—clutch housing to gearbox.
8(O)	Retainer—clutch release bearing.	25.	Tab washer—clutch intermediate rod.		

E THE CLUTCH

lugs by means of struts (17) which provide knife-edge contact between the outer ends of the levers and the pressure plate lugs, eliminating friction at this point. Thus the pressure plate (18) is pulled away from the driven plate (3), compressing the six thrust coil springs (5) which are assembled between the pressure plate (18) and the clutch cover (4).

When the foot pressure is removed from the clutch pedal the clutch springs force the pressure plate forward against the driven plate, gradually and smoothly applying the power to the rear wheels.

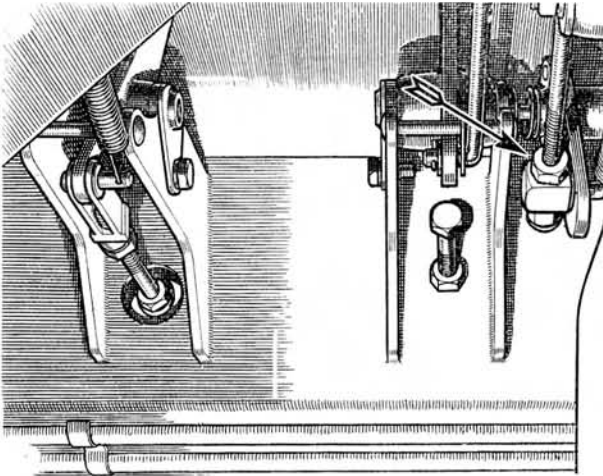

Fig. E.2.
Clutch pedal adjustment points.

Section E.1

RUNNING ADJUSTMENTS

The only adjustment necessary throughout the life of the driven plate friction facings is to restore the free movement of the clutch pedal periodically. As the driven plate facings wear, the free movement of the clutch pedal will gradually decrease ; when it is reduced to $\frac{1}{2}$ in. (12.7 mm.), measured at the pedal pad, it must be reset to $\frac{3}{4}$ in. (19 mm.) as follows :—

There are two points to check.

1. At the screwed rod shown in Fig. E.2. In this case, the locknut, is slackened back and the $\frac{3}{4}$ in. (19 mm.) clearance is set at this point.
2. At the clutch stop shown in Fig. E.2, when the clutch is completely withdrawn there must be a further movement of $\frac{1}{2}$ in. (12.7 mm.) at the pedal.

Note.—Over-travel of the release bearing leads to solid coiling of the thrust springs, and this brings undue stress on the internal parts of the clutch and to the graphite release bearing in particular, which will wear extremely rapidly under these conditions.

Section E.2

REMOVING THE CLUTCH

Remove the power unit from the car ; see Section A. Remove the gearbox as in Section F.

Loosen each of the bolts securing the clutch to the flywheel by slackening them a turn at a time until the spring pressure is released.

The clutch cover can then be disengaged from the flywheel dowels and the whole assembly lifted from the flywheel, all parts except the driven plate remaining assembled in the cover.

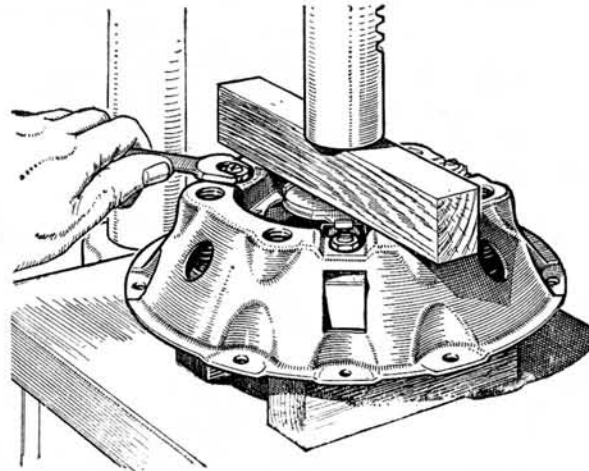

Fig. E.3.

The correct procedure to adopt when dismantling the clutch cover assembly. Note the two wood blocks supporting the pressure plate on the bed of the press. These must not project beyond the pressure plate or they may foul the cover-plate when this is depressed.

Section E.3

DISMANTLING THE CLUTCH

(See Section E.9 for use of universal clutch gauging fixture.)

Mark the following parts so that they can be re-assembled in the same relative positions to preserve the balance and adjustment : cover (4), pressure plate lugs (18) and release levers (12).

Detach the release lever plate (10) from the retainer springs (11) and place the cover assembly under a press with the pressure plate (18) resting on blocks of such a size that the cover is free to move downwards when pressure is applied. (See Fig. E.3.)

Place a block of wood across the top of the cover, resting on the spring bosses.

Compress the cover and remove the adjusting nuts (14) and slowly release the pressure to prevent the thrust springs (5) from flying out.

Lift off the cover to expose all parts for inspection.

Remove each release lever (12) by grasping the lever and eyebolt (15) between finger and thumb so that the inner end of the lever and the threaded end of the eyebolt are as near together as possible, keeping the eyebolt pin in position in the lever.

Lift the strut (17) over the ridge on the lever and remove the eyebolt (15) from the pressure plate.

Section E.4

ASSEMBLING THE CLUTCH

Before assembly, thoroughly clean all parts and renew those which show appreciable wear.

Place the pressure plate on the blocks under the press and place the thrust springs (5) in a vertical position on the plate, seating them on the bosses provided.

Assemble the release levers (12), eyebolts (15) and floating pins (16), holding the threaded end of the eyebolt and inner end of the lever as close together as possible. With the other hand insert the strut (17) in the slots on the pressure plate lug sufficiently to allow the plain end of the eyebolt to be inserted in the hole in the pressure plate. Move the strut upwards into the slot in the pressure plate lug and over the ridge on the short end of the lever, and drop it into the groove formed in the lever. Fit the remaining levers in a similar manner, taking care that they are being refitted into their original positions.

Lay the cover (4) over the assembled parts, ensuring that the anti-rattle springs (13) are in position and that the tops of the clutch springs are directly under the seats in the cover, also that the machined portions of the pressure plate lugs are directly under the slots in the cover through which they have to pass. Also ensure that the parts marked before dismantling are in their correct relative positions to maintain correct balance.

Place the block of wood across the cover as in Fig. E.3, and compress the clutch springs by means of the press spindle, guiding the eyebolts and pressure plate lugs through the holes in the cover.

Screw the adjusting nuts (14) on the eyebolts (15) and secure by staking or split pins in accordance with the system originally used by the makers.

Remove the clutch from the press, and assemble the lever plate (10) on the tips of the levers (12) and retainer springs (11).

Note.—If new parts have been fitted, which may affect the adjustment, the levers should be set, using the gauge plate, Part No. CG.13422, as indicated in Section E.6.

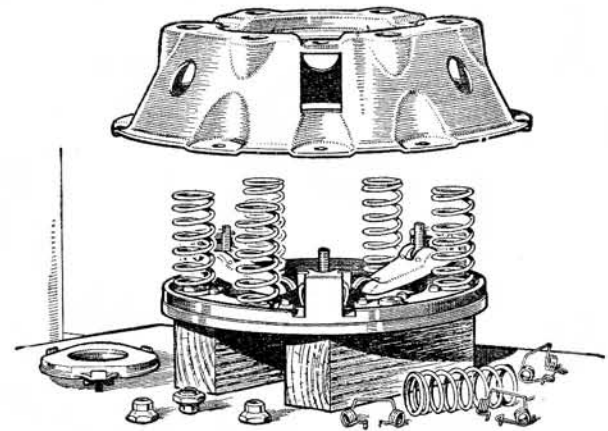

Fig. E.4.

Showing the component parts of the clutch assembly.

Section E.5

REFITTING THE CLUTCH

To refit the clutch to the flywheel proceed as follows :—

Assemble the driven plate assembly in the flywheel (1), taking care to place the larger chamfered spline end of the driven plate hub towards the gearbox or the rear of the vehicle.

Centralise the driven plate by means of a clutch alignment bar, which fits the splined bore of the driven plate hub and the pilot bearing in the flywheel. As an alternative a spare gearbox driving gear and shaft can be used.

Fit the cover assembly to the flywheel by means of the securing bolts (2), tightening them a turn at a time by diagonal selection. Do not remove the clutch alignment bar until all the bolts are securely tightened.

Remove the clutch alignment bar and refit the withdrawal bearing and the gearbox. The weight of the gearbox must be supported during refitting in order to avoid strain on the shaft and distortion or displacement of the driven plate assembly.

(Reference numbers apply to Fig. E.1.)

Section E.6

ADJUSTING THE RELEASE LEVERS

Satisfactory operation of the clutch is dependent on accurate adjustment of the release levers (12). This must be carried out before the clutch has been assembled to the flywheel and should only be necessary if new parts have been fitted. The maximum difference allowed in the height of the levers is .015 in. (.38 mm.). To obtain a setting within this limit use the special gauge plate (or universal clutch gauging fixture) in conjunction with the rest of the clutch assembly

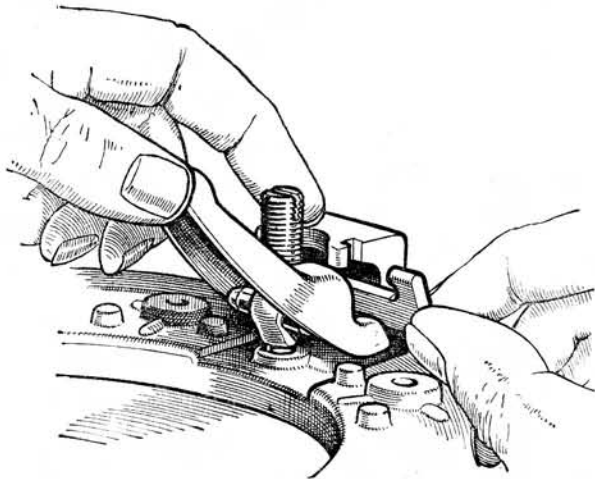

Fig. E.5.

To assemble the levers hold the threaded end of the eyebolt and lever close together as shown and insert the struts in the slots of the pressure plate lugs sufficiently to permit the plain end of the eyebolt to be inserted in the hole in the pressure plate.

and the flywheel. Proceed as follows :—Place the gauge plate, Part No. CG.14322, centrally in the flywheel in place of the driven plate. Fit the cover assembly to the flywheel by tightening the securing bolts (2) a turn at a time by diagonal selection until fully secured. Place a straight-edge across the gauge plate boss and the tip of one release lever (Fig. E.6) and adjust the release lever, if necessary, by turning the adjusting nut (14) until the tip of the lever is exactly level with the top of the gauge boss. Adjust the remaining levers in a similar manner. The setting should be within .005 in. (.13 mm.).

Re-lock the eyebolt nuts by the same method used by the makers (split pin or staking).

Slacken the securing bolts (2) a turn at a time by diagonal selection, then remove the holding screws and the clutch from the flywheel (1). Remove the gauge plate and reassemble with the actual driven plate.

Section E.7

REFACING THE DRIVEN PLATE

To renew the facings on the driven plate, proceed as follows :—

Do not punch out the rivets.

Using a $\frac{5}{32}$ in. or 4 mm. drill, remove each rivet.

Rivet one new facing in position, using a blunt-ended centre punch if the correct tool is not available to roll the rivet shanks against the plate.

Rivet the second facing onto the opposite side of the plate with the clearance holes over the rivet heads already formed in fitting the first facing.

Mount the plate on a mandrel between centres and check for run-out as near the edge as possible ; if error is more than .015 in. (.38 mm.), dress over the high spots until true within this figure.

Section E.8

SERVICING THE CLUTCH

As the clutch facings wear the pressure plate moves closer to the flywheel face, and the outer or shorter ends of the release levers follow. This causes the inner or longer ends of the levers to travel farther towards the gearbox, and decreases the clearance between the release lever plate and the release bearing. Some free movement must be maintained here to prevent the release bearing riding against the release lever plate, causing excessive wear on the release bearing with the added possibility of clutch slip. The free pedal movement, measured at the pedal pad, should be $\frac{3}{4}$ in. (19 mm.).

Excessive pedal movement causes coil binding of the springs and imposes an undue load on the bearing and on the crankshaft, causing excessive and rapid bearing wear. It therefore follows that the required pedal travel is the sum of the two movements :—

1. *The free movement*, or travel necessary to take up the clearance between the release bearing and the release plate, provided to ensure that the clutch is fully engaged when the foot is removed from the pedal.
2. *The effective movement*, or travel necessary to release the clutch, i.e. the amount of effective pedal movement necessary to move the release plate the distance required to free the clutch completely.

The pedal travel is limited by the front (fixed) and back (adjustable) stops. The back stop should be adjusted to provide $\frac{1}{2}$ in. (12.7 mm.) further travel at the pedal pad end from a point when the clutch is just released. This release point can be found by starting the engine and depressing the clutch pedal half of the total travel. GENTLY move the gear change lever towards first gear, at the same time gradually depressing the clutch pedal. When the gear engages silently and easily the clutch is released and the pedal should only move a further $\frac{1}{2}$ in. to the back stop.

If any difficulty is experienced in freeing the clutch, on no account should efforts be made to improve matters by attempting to increase the effective pedal travel. The actual cause of the trouble must be ascertained and rectified.

To obtain a clean release, the release lever plate should move a distance of $\frac{5}{16}$ in. (7.9 mm.) towards the flywheel.

Spring pressure

A tolerance of not more than 10 lb. to 15 lb. (4.5 kg. to 6.8 kg.) pressure is allowable on the compression load of the operating springs when at their assembled height, and all clutch springs are tested for this before assembly.

The clutch operation springs are not affected by high clutch temperatures, as the pressure plate absorbs heat rapidly, the springs have only line contact, and a draught is continually passing under them when the engine is running.

Tolerances

Wear on the working faces of the driven plate is about .001 in. (.02 mm.) per 1,000 miles (1600 km.) under normal running conditions. The accuracy of the alignment of the face of the driven plate must be within .015 in. (.38 mm.).

Driven plates

It is important that the clutch facings are not touched with greasy hands, nor any oil or grease allowed to come into contact with them.

Lubrication of the splines of the driven plate is provided at assembly only, when CS881 graphite grease or Duckham's Keenolised Grease K624 is used.

It is essential to install a complete driven plate assembly when renewal of the friction surfaces is required. If the facings have worn to such an extent as to warrant renewal, then slight wear will have taken place on the splines, and also on the torque reaction springs and their seatings. The question of balance and concentricity is also involved. Under no circumstances is it satisfactory to repair or rectify faults in clutch driven plate centres, and we do not countenance this as manufacturers.

Condition of clutch facings in service

It is natural to assume that a rough surface will give a higher frictional value against slipping than a polished one, but this is not necessarily correct. A roughened surface consists of small hills and dales, only the "high spots" of which make contact. As the amount of useful friction for the purpose of taking up the drive is dependent upon the area in actual contact, it is obvious that a perfectly smooth face is required to transmit the maximum amount of power for a given surface area.

Since modern facing materials of the asbestos type have been introduced in service the polished surface is common, but it must not be confused with the glazed surface which is sometimes encountered due to conditions to be discussed subsequently. The ideally smooth or polished condition will therefore provide proper

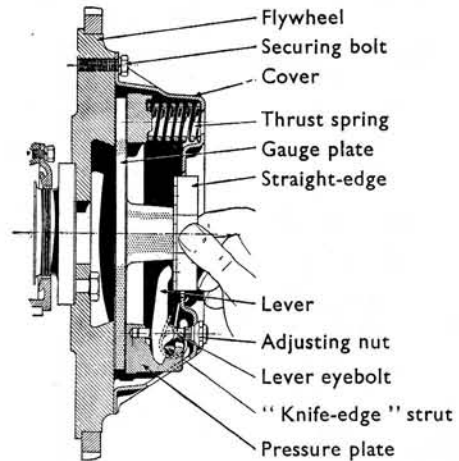

Fig. E.6.

Setting the release levers by means of the special gauge plate, Part No. CG.13422, and a short straight-edge.

surface contact, but a glazed surface entirely alters the frictional value of the surface, and will result in excessive clutch slip. These two conditions might be illustrated simply by comparison between a piece of smoothly finished wood and one with a varnished surface; in the former the contact is made directly by the original material, whereas in the latter instance a film of dry varnish is interposed between the contact surfaces, and actual contact is made by the varnish.

If the clutch has been in use for some little time under satisfactory conditions, the surface of the facings assumes a high polish through which the nature of the material can be seen clearly. This polished facing is of light colour when in perfect condition.

Should oil in small quantities gain access to the clutch and find its way onto the facings, it will be burnt off as a result of the heat generated by the slipping occurring under normal starting conditions. The burning of this small quantity of lubricant, has the effect of gradually darkening the facings, but provided the polish of the facings remains such that the nature of the material can be distinguished clearly it has little effect on clutch performance.

Should increased quantities of oil reach the facings, then one of two conditions, or a combination of these, may arise, depending upon the nature of the oil.

1. The oil may burn off and leave a carbon deposit on the surface of the facings, which assume a high glaze, producing further slip. This is a very definite, though very thin, deposit, and in general it hides the grain of the material.
2. The oil may partially burn and leave a resinous deposit on the facings. This has a tendency to produce a fierce clutch, and may also cause excessive "spinning" due to the tendency of

E THE CLUTCH

the face of the linings to adhere to the surface of the flywheel or pressure plate.

3. There may be a combination of conditions (1) and (2) which produces a tendency to "judder" on clutch engagement.

Still greater quantities of oil produce a dark and soaked appearance of the facings, resulting in further slip, accompanied by fierceness or "juddering" on engagement, according to the severity of the condition.

If the above conditions are experienced, the clutch driven plate should be replaced by a new one. **The cause of the presence of the oil must be traced and removed.** It is necessary for the clutch and flywheel to be cleaned out thoroughly before assembly.

Where the graphite release bearing ring is badly worn in service, a complete replacement assembly should be fitted, returning the old assembly for salvage of the metal cup. These graphite rings are inserted into their metal cups by heating the metal cup to a cherry red, then forcing the graphite ring into position. This is a specialised job, but it can be carried out satisfactorily provided the necessary care is exercised. Immediately the ring is forced into position, the whole should be quenched in oil. Alignment of the thrust pad in relation to its face and the trunnions should be within .005 in. (.12 mm.).

In almost every case of rapid wear on the splines of the clutch driven plate, misalignment is responsible.

Looseness of the driven plate on the splined shaft results in noticeable backlash in the clutch. Misalignment also puts undue stress on the driven member, and may result in the hub breaking loose from the plate, with consequent total failure of the clutch.

It may also be responsible for a fierce chattering or dragging of the clutch, making gear changing difficult. In persistent cases it is advisable to check the flywheel for truth with a dial indicator to determine any misalignment. The dial reading should not vary more than .003 in. (.07 mm.) round the flywheel face.

Section E.9

THE UNIVERSAL CLUTCH GAUGING FIXTURE

Remove from the box the gauge finger, the pillar and the actuator, as shown in Section Q and consult the code card to determine the reference of the adaptor and the spacers appropriate to the clutch which is being serviced.

Rest the base plate on a flat surface, wipe it clean and place the spacers upon it in the positions quoted on the code card.

Place the clutch on the spacers, aligning it with the appropriate tapped holes in the base, arranging it so that the release levers are as close to the spacers as possible.

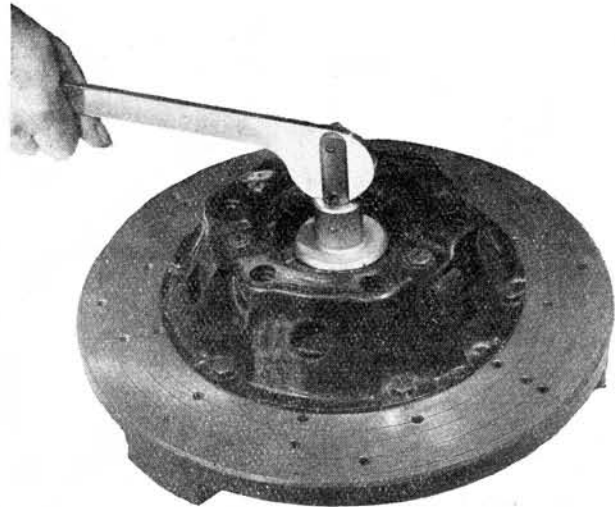

Fig. E.7.

Using the actuator to compress the clutch springs for dismantling or setting the assembly.

Screw the actuator into the centre holes in the base plate and press the handle down to clamp the clutch. Then screw the set bolts provided firmly into the tapped holes in the base plate using the speed brace ; remove the actuator.

Remove the adjusting nuts and gradually unscrew the set bolts to relieve the load of the thrust springs. Lift the cover off the clutch and carry out whatever additional dismantling may be desired.



Fig. E.8.

Checking the setting of the release levers.

After carrying out the necessary servicing of the clutch components, reassemble the parts on the clutch pressure plate, place the cover upon it and transfer the assembly to the base plate, resting on the spacers and aligned correctly.

Carefully bolt the cover to the base plate and screw the adjusting nuts on to the eye-bolts until flush with the tops of the latter.

Screw the actuator into the base plate (Fig. E.7) and pump the handle a dozen times to settle the clutch mechanism. Remove the actuator.

Screw the pillar firmly into the base and place upon it the appropriate adaptor, recessed face downwards, and the gauge finger (Fig. E.8).

Turn the adjusting nuts until the finger just touches the release levers, pressing firmly downwards on the finger assembly to ensure that it is bearing squarely on the adaptor.

Remove the finger, adaptor and pillar, replace the actuator and operate the clutch a further dozen times. Replace the pillar and check the lever setting, making any final corrections.

Finally, lock the adjusting nuts.

2. Remove the cotter and draw the coupling off the clutch shaft.
3. Cut off the end of the clutch shaft to the dimension shown, and remove any sharp edges.
4. Assemble the coupling on to the clutch shaft. Make sure that the cotter is correctly fitted,

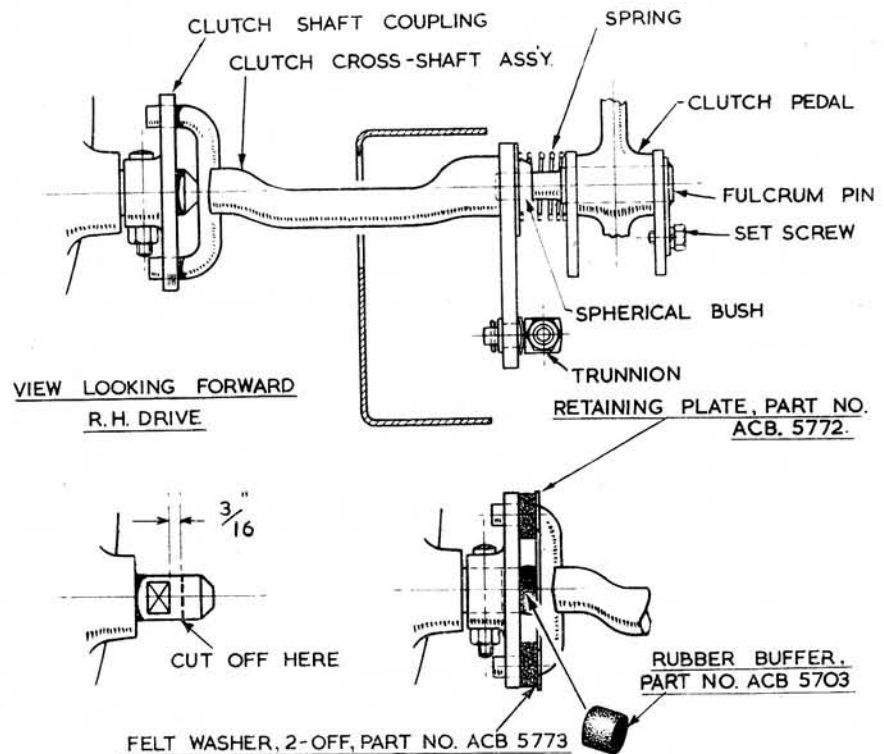

Fig. E.9.

Fitting a rubber buffer to the clutch cross-shaft.

Section E.10

FITTING A RUBBER BUFFER TO THE CLUTCH CROSS-SHAFT

If a rattle develops in the clutch cross-shaft it may be cured as follows :—

1. Prise the cross-shaft fork out of engagement with the coupling on the clutch shaft. (On some cars it may be necessary to remove the pedal fulcrum pin.) Disconnect the trunnion and remove the cross-shaft assembly.

i.e. with the threaded end downwards. If fitted the other way up, the angular position of the coupling would be incorrect.

5. Press the rubber buffer into the hole in the centre of the coupling. Thread the retaining plate and felt washers onto the cross-shaft fork.
6. Replace the cross-shaft assembly, making sure that the spherical bush is in the correct position to receive the end of the pedal fulcrum pin, and that the spring is in position.
7. Connect the trunnion to the cross-shaft lever.