

## SECTION R

(1½ and 2½ LITRE)

### THE BODY

Lubrication.

- Section No. R.1 Adjustments.
- Section No. R.2 To remove the body.
- Section No. R.3 Removing the windscreen.
- Section No. R.4 To remove the rear window.
- Section No. R.5 To change a side window.
- Section No. R.6 To remove the window-winding mechanism.
- Section No. R.7 To change a side window (front).
- Section No. R.8 To remove the boot door.
- Section No. R.9 To remove the steering column inner mast.
- Section No. R.10 To remove the steering wheel.
- Section No. R.11 To change the steering rubber bush.
- Section No. R.12 To remove the inner steering column.
- Section No. R.13 To change the roof covering.
- Section No. R.14 To remove the bonnet sides (2½ litre).
- Section No. R.15 To prevent water leaks at backlight.
- Section No. R.16 Standard heaters.

### LUBRICATION

An oil can filled with oil to Ref. F should be used sparingly on door locks, bonnet catch mechanism, seat catches and runners, boot hinges and spare wheel compartment lid and lock each 1,000 miles (1600 km.).

The door hinges are provided with grease nipples which should receive attention at intervals of 6,000 miles (10000 km.) from a grease gun filled with grease to Ref. D.

### Section R.1

#### ADJUSTMENTS

##### *The bonnet tops*

Correct bonnet fit is obtained by adjusting the four "U" shaped catches fitted on the under side of the

bonnet tops. The catches are screwed at the ends and may be lowered or raised by means of the nuts.

If they are not correctly set the bonnet will be a poor fit. Do not set the catches so that excessive strain is imposed on the stiffening members.

##### *The front seats*

The front seats are adjustable in a fore and aft direction by means of spring-loaded catches.

##### *The doors*

When closed and correctly adjusted, the doors will be a good tight fit on the rubber dust and draught excluders.

In order to set the doors correctly the door striker plates should be slackened back and positioned so that no rattles or draughts are experienced.

# CHASSIS DETAILS (2½ and 1½ LITRE)

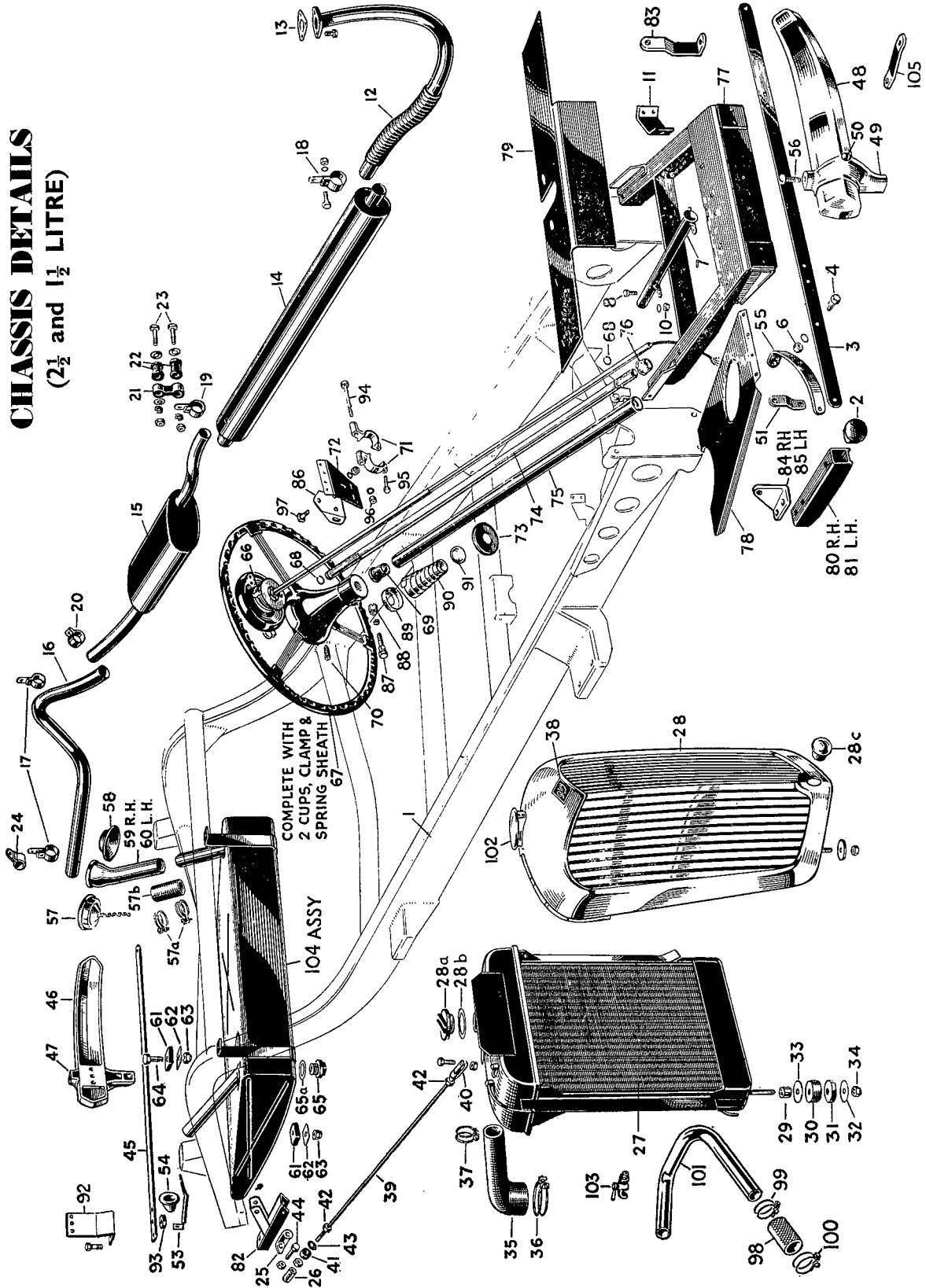

## KEY TO CHASSIS DETAILS (2½ AND 1½ LITRE)

No.	Description	No.	Description	No.	Description
1.	Frame assembly.	36.	Clip—radiator hose.	70.	Steering wheel grub screw.
2.	Plug—jack tube.	37.	Clip—radiator hose.	71.	Clamp—steering column steady.
3.	Cross-rail—front bumper.	38.	Badge—radiator.	72.	Bracket—steering column steady clamp.
4.	Bolt—front bumper cross-rail.	39.	Rod—radiator steady.	73.	Seal—steering column.
6.	Nut—front bumper cross-rail.	40.	Jaw—radiator steady rod.	74.	Tube—steering column (inner).
7.	Tube assembly—starting handle.	41.	Rubber washer—radiator steady rod.	75.	Tube—steering column (outer).
8.	Bolt—starting handle tube.	42.	Nut—radiator steady rod.	76.	Nut—inner tube retaining.
10.	Nut—starting handle tube bolt.	43.	Washer—plain—radiator steady rod.	77.	Front extension.
11.	Bracket—horn—R/H (early models).	44.	Bolt—steady rod bracket to body.	78.	Bottom support—front extension.
12.	Exhaust pipe (front)—complete.	45.	Cross-rail—rear bumper.	79.	Cowling (front).
13.	Gasket—front exhaust pipe.	46.	Bumper (rear).	80.	Tube assembly—jack R/H.
14.	Silencer assembly.	47.	Over-rider—rear bumper.	81.	Tube assembly—jack L/H.
15.	Expansion box assembly.	48.	Bumper (front).	82.	Tube—rear jack.
16.	Tail pipe.	49.	Over-rider—front bumper.	83.	Plate—front bumper support.
17.	Clip—tail pipe.	50.	Plug—front bumper over-rider (rubber).	84.	Bracket—R/H—jack channel.
18.	Clip—front—silencer.	51.	Front bumper support plate.	85.	Bracket—L/H—jack channel.
19.	Clip—rear—silencer.	53.	Bracket—rear bumper.	86.	Bracket—steering column clamp.
20.	Clip—rear pipe.	54.	Grommet—rear bumper.	87.	Steering wheel clamp bolt and nut.
21.	Link—clip bush.	55.	Support—front bumper.	88.	Retaining washer for spring (top).
22.	Bush for link.	56.	Set screw—front bumper over-rider.	90.	Spring for steering wheel.
23.	Pin—link.	57.	Cap and chain—petrol tank.	91.	Retaining washer for spring (bottom).
24.	Bracket—tail pipe support.	57a.	Clip—petrol tank filler hose.	92.	Support—rear bumper bracket.
25.	Bracket—radiator steady rod.	57b.	Hose—petrol tank filler.	93.	Washer—rear bumper distance.
26.	Bush—radiator steady rod.	58.	Grommet—petrol tank filler.	94.	Bolt (C.P.)—steering column steady clamp.
27.	Block—radiator.	59.	Filler—petrol tank R/H.	95.	Bolt (C.P.)—steering column steady clamp.
28.	Shell and grille—radiator.	60.	Filler—petrol tank L/H.	96.	Nut (C.P.)—steering column steady clamp.
28a.	Cap—radiator filler.	61.	Mounting rubber—petrol tank.	97.	Bolt—steering column clamp bracket.
28b.	Washer—radiator cap.	62.	Mounting washer—petrol tank.	98.	Hose—radiator (bottom).
28c.	Cap—radiator shell starting handle.	63.	Nut—petrol tank mounting bolt.	99.	Clip—radiator hose (bottom).
29.	Distance-piece—radiator mounting.	64.	Bolt—petrol tank mounting.	100.	Clip—radiator hose (bottom).
30.	Mounting rubber—radiator (top).	65.	Drain plug and filter—petrol tank.	101.	Bottom water pipe.
31.	Mounting rubber—radiator (bottom).	65a.	Washer—petrol tank drain plug.	102.	Dummy cap—radiator shell.
32.	Washer—radiator mounting (bottom).	66.	Steering column control.	103.	Radiator drain tap.
33.	Washer—radiator mounting (top).	67.	Steering wheel (complete).	104.	Petrol tank assembly.
34.	Nut—radiator mounting bolt.	68.	Circlip—steering column inner tube.	105.	Bracket—spot-lamp.
35.	Hose—radiator top.	69.	Bush—steering column outer tube.		

## Section R.2

### TO REMOVE THE BODY

When removing the body it is essential that the slinging tackle be fixed at two points adjacent to the boot hinges, with the boot lid raised, and under the forward mounting brackets, otherwise the body will be distorted.

Start on this job by sliding the front seats as far back as they will go and then lifting them out. In order to free the runners it may be necessary to tilt the seat upwards as it nears the rear seat. Now take up the carpets.

Unscrew the retaining screws holding the floorboards and remove them from the car, together with the gearbox tunnel, which can be taken off by removing the gear lever knob, unscrewing the retaining plate at the rear end and turning the two catches, one at either side, through 90 degrees.

Next remove the steering wheel and column as explained in Sections R.9 to R.12.

Take off the bonnet top and sides (Sections D.2 and R.14).

Remove the front wings (Section K.3).

The next stage is to take off the flat cover over the intermediate shaft and lift out the rear seat cushion.

Disconnect both battery leads, release the battery retaining bolts by unscrewing the two wing nuts from inside the parcel tray, and lift the battery away. Then disconnect the starter motor cable at the solenoid,

which is located on the engine bulkhead. Earlier cars had the solenoid mounted on the starter motor itself.

Disconnect all the cables at the snap-in connectors so that no cable connections occur between the body and chassis.

Disconnect the reverse light cable at the gearbox switch.

Detach the hydraulic fluid supply tank from the bulkhead by removing the retaining bracket. Tie the tank to the rear carburetter.

Disconnect the L.T. cable to the distributor and undo the oil pressure gauge pipe at the double union near the bulkhead.

Take off the air cleaner so that it will be easier to detach the hand throttle cable, rich mixture control, and the ignition control.

Detach the hand brake cable and remove the small connecting link in the throttle control system.

From the inside of the car take off the accelerator pedal pad.

Next, push the accelerator pedal through the hole in the body and twist it slightly so that it clears the accelerator stop.

Disconnect the speedometer cable at the gearbox end and tie it to the body. Unscrew the union nut on the thermostat and remove the thermometer unit. Unclip the thermometer pipe from the radiator steady rod and detach the rods.

Disconnect the rear light cables at the lamps themselves and free the cables from the body.

CROSS-MEMBER FITTED IN PLACE OF BRACKETS ON 2 SEATER CHASSIS, BUT BOLT LOCATION HOLES REMAIN IN SAME POSITION.

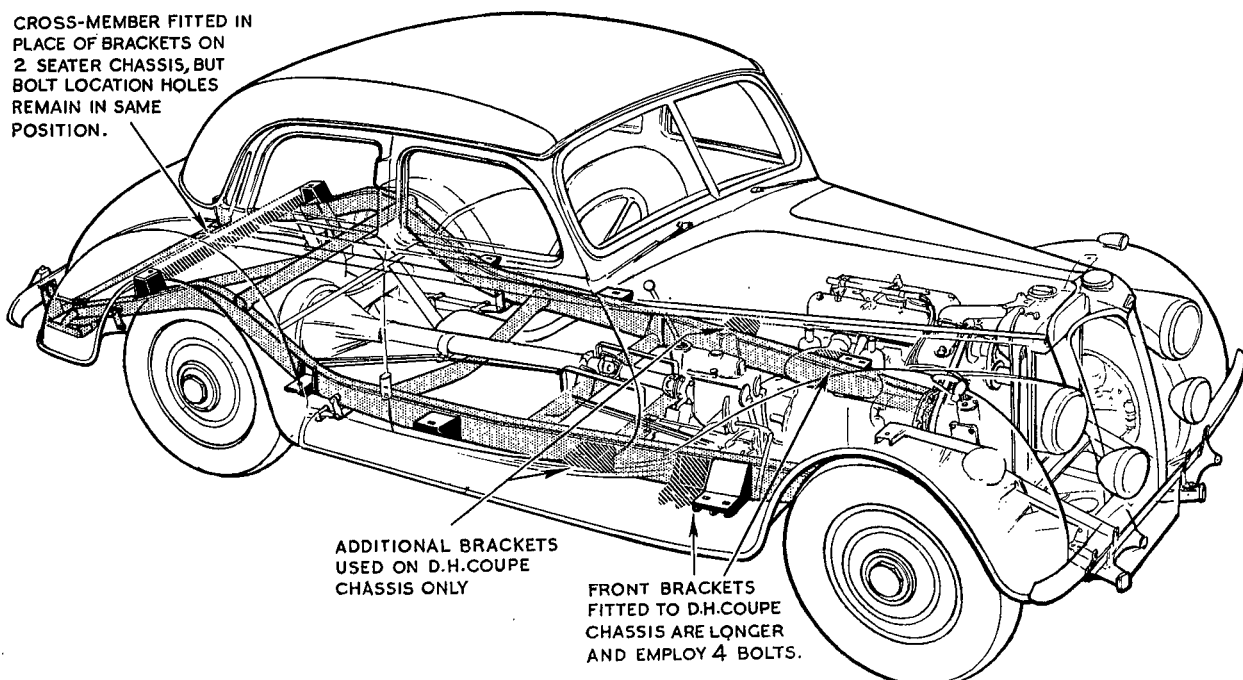

Fig. R.1.

This diagram shows the location of the body mounting brackets for the 1½ litre and 2½ litre saloons and the 2½ litre coupé.

Take off the rear bumper assembly complete and remove the upper brackets from the bumpers. These are the brackets that actually pass through holes in the body shell.

The body is now ready for removal after the ten fixing bolts have been taken out. These bolts are located as follows :—Two on each front bracket located close to the front end of the silencer on one side and similarly on the other, one on each bracket under the door posts and one on each side just forward of the wheel arches. Finally, two bolts enter brackets via holes in the floor of the luggage boot. These bolt heads may be reached by raising the floor covering.

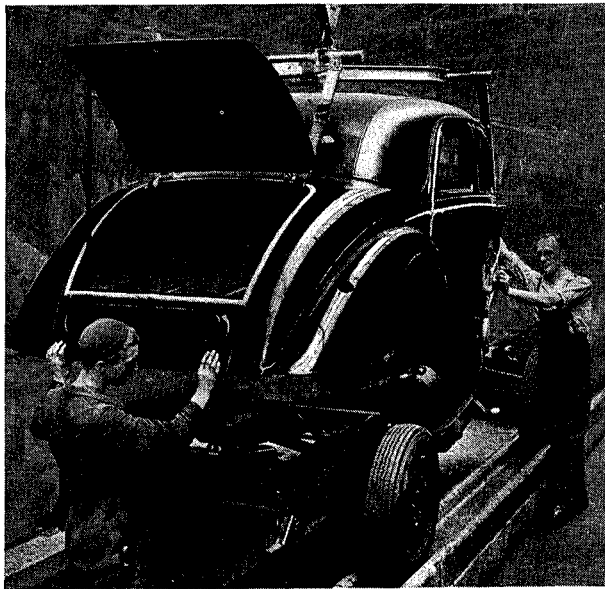

Fig. R.2.

Note the sling attachment points when lifting the body from the chassis.

## Section R.3

### REMOVING THE WINDSCREEN

Slacken the two nuts behind the fascia panel at the outer ends. There are two slotted brackets here. Remove the two Phillips screws on the front face of the chromium-plated control panel. This will then allow the complete panel to fall away to expose the bottom screen fixings.

Now take out the top trim, which is held in place by seven Phillips screws. Note that two of them are longer than the other five and must be replaced in the same position.

Take off the side fillets, which are each held by three Phillips screws.

Remove the lower run of beading and undo the twelve screen-retaining screws (four at the top and

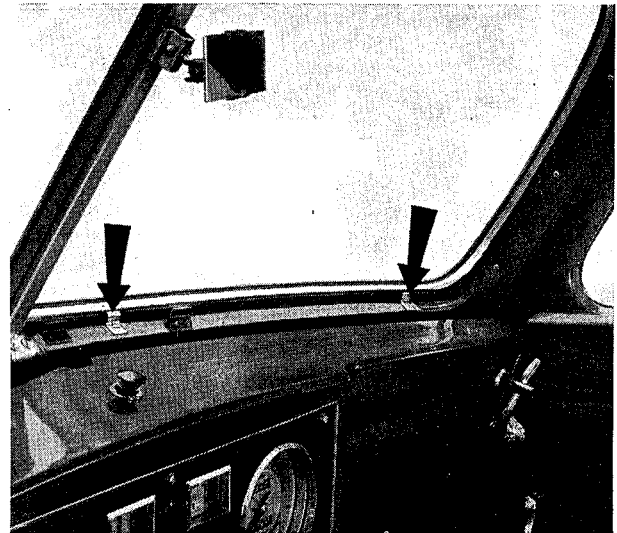

Fig. R.3.

Two of the windscreen locating clips.

eight at the bottom). The screen will then push straight forward.

**Note.**—When refitting, seal all joints with Bostik.

## Section R.4

### TO REMOVE THE REAR WINDOW

This is a simple operation. The beading must be removed by taking out the ten Phillips screws. The window can then be pushed towards the inside of the car.

## Section R.5

### TO CHANGE A SIDE WINDOW

Start off by removing the walnut capping which is held in place by six Phillips screws. Then detach the inside door knob by pressing back the spring-loaded cover and extracting the retaining pin. The handle will then pull away complete with spring and cover.

The window winder can be taken off in a similar manner.

The complete door trim panel can now be removed and it should carefully be prised away from the door frame with a screwdriver. The panel is held by steel pins all round except at the top where there are three small woodscrews.

The window winder mechanism is fixed to the large wooden panel behind the door trim and the next thing to do is to take out the two Phillips screws on the front edge of the door lock.

It is now possible to remove the thirteen woodscrews holding the window-winding panel to the door. Note that five of these screws hold the window sill,



Fig. R.4.

Removing the door trim prior to detaching the window-winding mechanism.

which must be taken off before the panel comes away.

The panel may now be eased out of position.

The window itself is a press fit in its rubber-lined channel.

## Section R.6

### TO REMOVE THE WINDOW-WINDING MECHANISM

Proceed as explained in Section R.5, when it will be found that the window-winding mechanism is fitted



Fig. R.5.

The window-winding mechanism is secured to a readily detachable sub-assembly.

to the large wooden panel, forming a sub-assembly, which is easily detachable as a complete unit.

## Section R.7

### TO CHANGE A SIDE WINDOW (FRONT DOOR)

The procedure to adopt in this case is basically similar to the method described in Section R.5, but in this instance the winder mechanism is carried on a smaller wooden panel located near the winding handle.

## Section R.8

### TO REMOVE THE BOOT DOOR

Removal of the boot door is a simple procedure when once the six hinge nuts have been undone. Do not forget to detach the lid support strut.

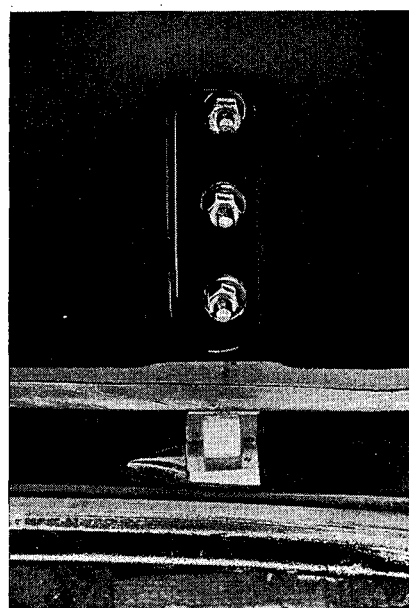

Fig. R.6.

The boot door hinge nuts (R/H side).

## Section R.9

### TO REMOVE THE STEERING COLUMN INNER MAST

Disconnect the cables at the snap-in connectors at the steering gearbox end.

Take off the brass ferrule where the cables pass through the steering gearbox.

Undo the three screws on the steering wheel boss and the inner mast can then be pulled straight upwards. Note that the mast is in two pieces.

## Section R.10

### TO REMOVE THE STEERING WHEEL

Take out the inner mast as explained in Section R.9.

Take off the spring-retaining ring and slacken the bolt which clamps the steering wheel to its splined column.

The wheel can now be pulled straight upwards complete with two collars and the telescopic sleeve.

## Section R.11

### TO CHANGE THE STEERING RUBBER BUSH

Remove the inner mast (see Section R.9).

Remove the steering wheel (see Section R.10).

Remove the chromium-plated clamp bolt holding the column to a bracket under the dash.

Remove the clamp bolt on the clip at the lower end of the steering column. (This is just above the steering gearbox.)

Pull the outer cover tube of the steering column upwards and pick out the bush. In extreme cases it may be necessary to tap on the clamp with a mallet in order to free the outer column.

**Note.**—If binding on the rubber bush is experienced it may be freed by using a reamer.

## Section R.12

### TO REMOVE THE INNER STEERING COLUMN

Take out the inner mast (see Section R.9).

Remove the steering wheel (see Section R.10).

Remove the outer column (see Section R.11).

Remove the circlip at the coupling on the lower end of the inner steering column.

Undo the locking nut with a "C" spanner and pull the column upwards.

## Section R.13

### TO CHANGE THE ROOF COVERING

Remove the rear window as explained in Section R.4.

Prise off the drip moulding, which will have to be renewed after the new cover has been fitted. Untack the covering and strip it right off, together with the layer of hessian and wadding.

Place the new wadding over the roof, adding strips at the joins in the perforated metal.

The wadding must be absolutely flat and the layer increased at any points where the perforated metal might be lower than the general contour. The wadding should be trimmed slightly short to allow for stretch when the outer covering is fitted.

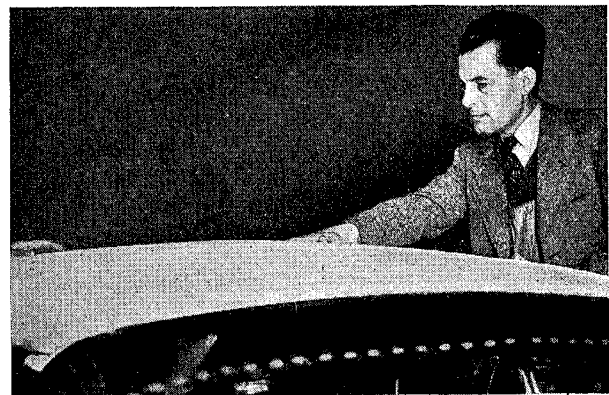

Fig. R.7.

Fitting the roof wadding calls for skill.

Rubber solution should be used to fix the wadding on the curves of the rear quarters only.

Next, lay the hessian in position and tack it in place. Cut out the aperture for the rear window and fix the edge with rubber solution and tacks. Use only galvanised steel tacks, to prevent rust.

Tacking should start at the rear and then the sides, pulling the hessian tightly in position over the curve of the roof. **Do not tack on the front edge.**

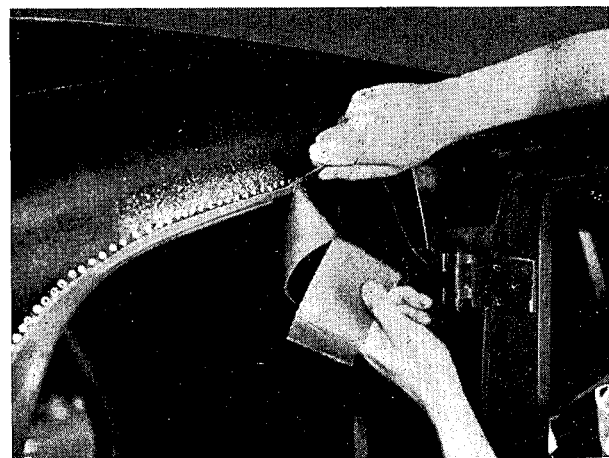

Fig. R.8.

Paring off the surplus material after nicking and final tacking.

Now mark off the positions of the seams of the outer cover on to the hessian. These seams come 20 inches from the centre line of the car on each side.

Slightly damp the under sides of the seams with water and position the outer cover. The water assists in the removal of any creases that might form.

The roof outer covering is a special material with a two-way stretch and great care must be taken to see that it is stretched tightly and firmly in position.

With the fabric in place, insert a few temporary tacks in position at the front and then stretch the

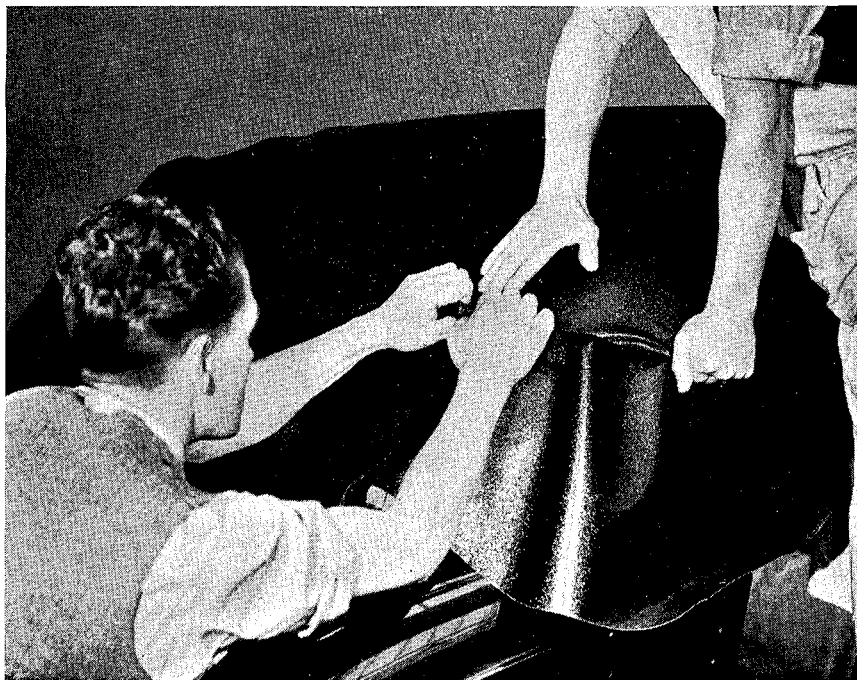

Fig. R.9.  
The roof covering must be stretched tightly in position and great care is necessary to see that creases or folds do not occur.

material down towards the rear of the body, tacking it temporarily in position at the back.

Now untack and pull the fabric at the front, getting the seams accurately in position, and then tack permanently in position. Return to the rear of the car and stretch the fabric again; tack it permanently this time.

Pull the fabric tight at the corners and work it round the curves of the rear quarters until the material fits snugly, taking care to keep the seams straight, and tack in position.

Rubber solution must be applied at the front corners.

Next, mould the shape of the rear window with a suitable piece of wood and cut out a panel, leaving approximately 1½ inches all round. Then apply rubber

solution and nick the material so that it takes the shape of the aperture. Tack it in position.

The covering is ready for final tacking now and the tacks should be located at approximately ½ in. intervals all round the roof.

The next operation is to nick the edges of the material overhanging and pare it off as near to the tack heads as is practicable.

Fitting the drip moulding is the final operation and great care should be exercised when bending this round the curve at the rear. Close the moulding up with a block of hard wood and a hammer as the operation of fixing proceeds.



Fig. R.10.  
Cutting surplus material from the back window aperture prior to tacking.

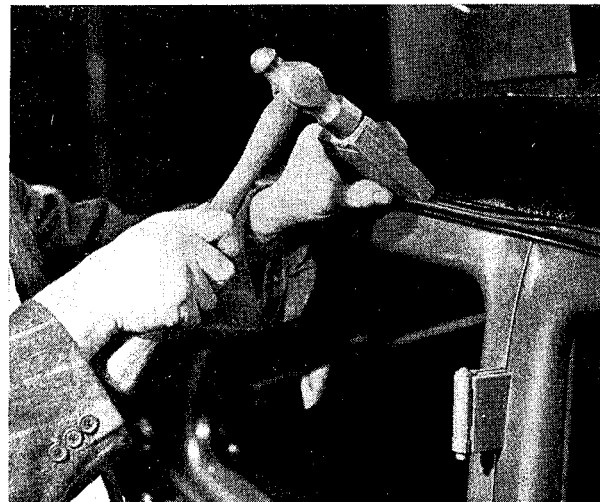

Fig. R.11.  
Final tapping over of the drip moulding.

### Section R.14

#### TO REMOVE THE BONNET SIDES

(2½ litre)

Should it be deemed necessary to remove the bonnet sides on the 2½ litre cars, this operation may easily be carried out after the bonnet top has been raised. It is not necessary to take the bonnet tops off to facilitate this operation ; they should, however, be retained in a vertical position by the catches which are installed for this purpose.

It will be found that the forward end of the bonnet side is secured by a screw and bolt ; these should be removed with a suitable spanner and screwdriver.

At the rear the connection between the bonnet side and the forward portion of the scuttle is effected by means of two screws and nuts which pass through a small extension bracket spot welded to the bonnet side. These nuts and screws should be undone, again with a suitable spanner and screwdriver.

The forward end, or the rear end, of the bonnet catch connecting rod should be disconnected by pinching up the open ends of the split pin with a pair of

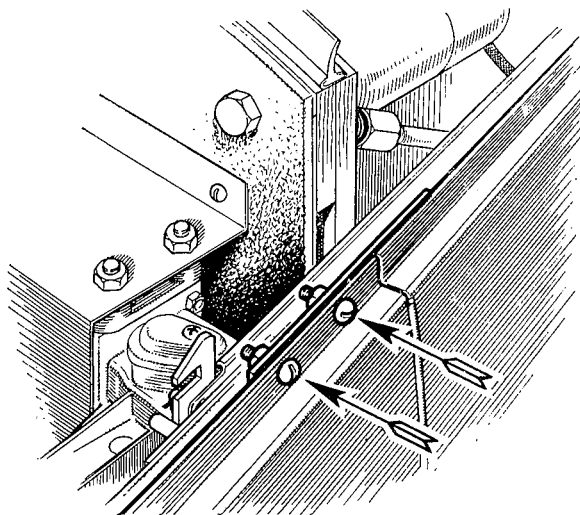

Fig. R.12.

The location of the screws which attach the rear end of the bonnet sides on the 2½ litre cars.

pliers and extracting the split pin and clevis pin ; this will free the connecting rod which can then be swung aside to a suitable position where it causes no obstruction.

When these operations have been completed the bonnet side may be lifted from the car and placed on one side where it will be clear of accidental damage.

### Section R.15

#### TO PREVENT WATER LEAKS AT THE BACKLIGHT

Remove the backlight assembly as detailed in Section R.4 and strip off the inside roof cloth.

Check that the four flat plates screwed to the inside of the backlight wood frame protrude evenly ⅜ in. around the aperture, and correct any unevenness. Make sure that the edges of the plates are flat and in line with each other all round. The gap between the joints of the plates is intentional and should be filled with Bostik or "Dum Dum" to give an unbroken surface.

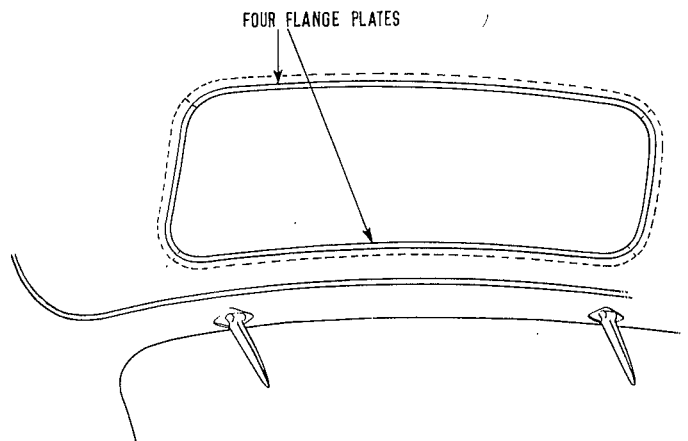

Fig. R.13

The flange plates around the inside of the framing.

Solution the new roof cloth over and around the flat plates, and then cut the cloth to leave a good ⅛ in. between the edge and the leather surface of the opening. Apply a small bead of Seelastik in the corner all round.

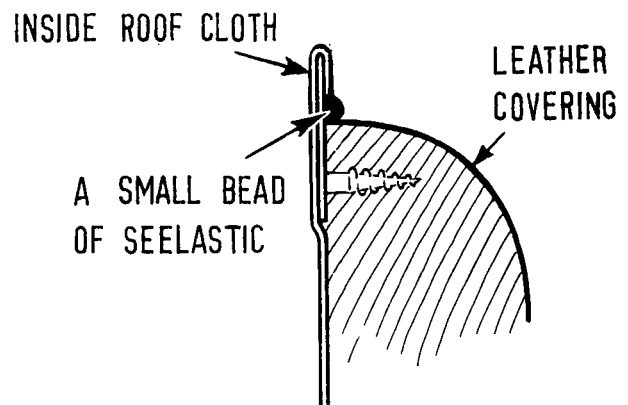

Fig. R.14

Location of "Seelastik" in the corner.

# R THE BODY

(1½ and 2½ LITRE)

Before refitting the backlight assembly, apply a small bead of Seelastik to the underside of the rubber lip to form a further seal on the leather covering.

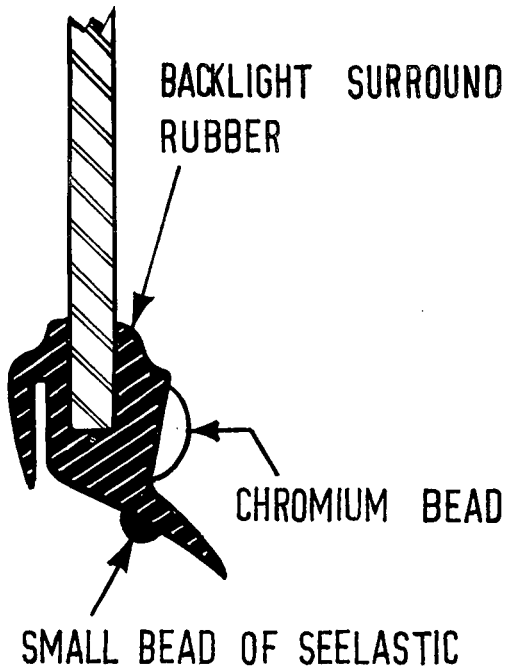

Fig. R.15

Backlight surround rubber in position

## Section R.16

### STANDARD HEATERS

Commencing at Chassis No. RME21644 the 1½ litre Riley has been fitted with the Gallay heater as a standard fitting.

This has introduced the following new parts :—

ACH.5016 Gallay heater (complete with No. 31 B.T. kit) ... .. 1

Comprising :—

ACH.5017	Heater with flex	...	...	...	1
ACH.5018	Strap—mounting	...	...	...	1
ACH.5019	Felt strip	...	...	...	1
ACH.5020	Plate—mounting	...	...	...	1
ACH.5021	Block—mounting	...	...	...	2
ACH.5022	No. 31 B.T. kit	...	...	...	1
ACH.5023	Two-way cock	...	...	...	1
ACH.5024	Hose—water—½ in.	...	...	...	9ft.
ACH.5025	Clip—hose	...	...	...	4
ACH.5026	Demister hose ends	...	...	...	2
ACH.5027	Demister air hose	...	...	...	4ft.
ACH.5028	Connector—engine tapping	...	...	...	1
ACH.5029	Washer—fibre—two-way cock	...	...	...	1
H.7953	Bracket—steering column (RHD)	...	...	...	1
H.7963	Clamp—steering column (RHD)	...	...	...	1
H.7971	Bracket—steering column (LHD)	...	...	...	1
H.7964	Clamp—steering column (LHD)	...	...	...	1

The following brackets are also utilised :—

H.7651	Bracket—steering column steady clamp	1
H.7652	Bracket—steering column clamp (RHD)	1
H.7654	Bracket—steering column clamp (LHD)	1

Commencing at Chassis No. RMF.10494 on the 2½ litre Riley the Smith type heater, which was previously an optional extra, became a standard fitting.

(1½ and 2½ LITRE)

## KEY TO RECOMMENDED LUBRICANTS

(EARLY CARS WITH SPIRAL BEVEL REAR AXLES)

<b>A</b> ENGINE AND AIR CLEANER								
<i>Climatic Conditions</i>	Mobiloil	Shell	B.P. Energol	Filtrate	Sternol	Duckham's	Castrol	Essolube
Tropical and Temperate down to 32° F. (0° C.)	Mobiloil "A"	"Shell" X-100 30	"Energol" S.A.E. 30	Medium "Filtrate" 30	"Sternol" W.W. 30	Duckham's N.O.L. "Thirty"	"Castrol" X.L.	"Essolube" 30
Cold and extreme cold down to 0° F. (-18° C.)	Mobiloil "Arctic"	"Shell" X-100 20/20 W	"Energol" S.A.E. 20 W	Zero "Filtrate" 20	"Sternol" W.W. 20	Duckham's N.O.L. "Twenty"	"Castrolite"	"Essolube" 20
Arctic—below 0° F. (-18° C.)	Mobiloil 10 W	"Shell" X-100 10 W	"Energol" S.A.E. 10 W	Sub-Zero "Filtrate" 10	"Sternol" W.W. 10	Duckham's N.O.L. "Ten"	"Castrol" Z	"Essolube" 10
<b>B</b> GEARBOX AND REAR AXLE								
Tropical and Temperate down to 10° F. (-12° C.)	Mobilube "G.X." 140	"Shell" Spirax 140 E.P.	"Energol" E.P. S.A.E. 140	E.P. "Filtrate" 140	Ambroleum E.P. 140	Duckham's N.O.L. 'E.P.' Transmission 140	"Castrol" Hi-Press	"Esso" Expee Compound 140
Extreme cold below 10° F. (-12° C.)	Mobilube "G.X." 80	"Shell" Spirax 80 E.P.	"Energol" E.P. S.A.E. 80	E.P. "Filtrate" 80	Ambroleum E.P. 80	Duckham's N.O.L. 'E.P.' Transmission 80	"Castrol" Hypoy 80	"Esso" Expee Compound 80
<b>C</b> WHEEL HUBS AND FAN AND WATER PUMP BEARINGS								
All conditions	Home—Mobil Hub Grease Export—Mobilgrease No. 5	"Shell" Retinax A	"Energol" C.3	Super Lithium "Filtrate" Grease	"Ambroline" L.H.T. Grease	Duckham's L.B. 10 Grease or H.B.B. Grease	"Castrol" Heavy	Home—"Esso" Grease Export—Hubs: "Esso" Bearing Grease Fan: "Esso" Chassis Grease
<b>D</b> STEERING GEARBOX, STEERING CONNECTIONS, KING-PINS, PROPELLER SHAFT, CLEVIS PINS AND LEVER FULCRUMS								
All conditions	Mobilgrease No. 2 or 4	"Shell" Retinax A	"Energol" C.1	Super Lithium "Filtrate" Grease	"Ambroline" L.H.T. Grease	Duckham's L.B. 10 Grease or H.P.G. Grease	"Castrol" Medium	Home—"Esso" Pressure Gun Grease Export—"Esso" Chassis Grease
<b>E</b> CABLES AND VITAL CONTROL JOINTS								
All conditions	Mobilgrease No. 2 or 4	"Shell" Retinax A	"Energol" C.1	Super Lithium "Filtrate" Grease	"Ambroline" L.H.T. Grease	Duckham's L.B. 10 Grease or "Keenol" K.G. 16 Grease	"Castrol" Brake Cable Grease	Home—"Esso" Pressure Gun Grease Export—"Esso" Chassis Grease
<b>F</b> UTILITY LUBRICANT, S.U. CARBURETTER DASHPOT, OILCAN POINTS, ETC.								
All conditions	Mobiloil "Arctic"	"Shell" X-100 20/20 W	"Energol" S.A.E. 20 W	Zero "Filtrate" 20	"Sternol" W.W. 20	Duckham's N.O.L. "Twenty"	"Castrolite"	"Essolube" 20

**EVERY 1,000 MILES (1600 Km.).** Use oilcan on all control joints, door locks, hinges.

(1½ and 2½ LITRE)

## KEY TO RECOMMENDED LUBRICANTS

### (Series RME and RMF)

The following is a list of recommended lubricants for use on the above models, which are fitted with Hypoid axles. **Only Hypoid oils must be used in the rear axle. Never mix lubricants.**

<b>A</b> ENGINE AND AIR CLEANER								
<i>Climatic Conditions</i>	Mobiloil	Shell	B.P. Energol	Filtrate	Sternol	Duckham's	Castrol	Essolube
Tropical and Temperate down to 32° F. (0° C.)	Mobiloil "A"	"Shell" X-100 30	"Energol" S.A.E. 30	Medium "Filtrate" 30	"Sternol" W.W. 30	Duckham's N.O.L. "Thirty"	"Castrol" X.L.	"Essolube" 30
Cold and extreme cold down to 0° F. (-18° C.)	Mobiloil "Arctic"	"Shell" X-100 20/20 W	"Energol" S.A.E. 20 W	Zero "Filtrate" 20	"Sternol" W.W. 20	Duckham's N.O.L. "Twenty"	"Castrolite"	"Essolube" 20
Arctic—consistently below 0° F. (-18° C.)	Mobiloil 10 W	"Shell" X-100 10 W	"Energol" S.A.E. 10 W	Sub-Zero "Filtrate" 10	"Sternol" W.W. 10	Duckham's N.O.L. "Ten"	"Castrol" Z	"Essolube" 10
<b>B</b> GEARBOX, STEERING GEARBOX AND REAR AXLE (HYPOID GEARS)								
Tropical and Temperate down to 10° F. (-12° C.)	Mobilube "G.X." 90	"Shell" Spirax 90 E.P.	"Energol" E.P. S.A.E. 90	Hypoid "Filtrate" 90	Ambroleum E.P. 90	Duckham's Hypoid 90	"Castrol" Hypoy	"Esso" Expee Compound 90
Extreme cold below 10° F. (-12° C.)	Mobilube "G.X." 80	"Shell" Spirax 80 E.P.	"Energol" E.P. S.A.E. 80	Hypoid "Filtrate" 80	Ambroleum E.P. 80	Duckham's Hypoid 80	"Castrol" Hypoy 80	"Esso" Expee Compound 80
<b>C</b> WHEEL HUBS AND WATER PUMP BEARINGS								
All conditions	Home—Mobil Hub Grease Export—Mobilgrease No. 5	"Shell" Retinax A	"Energol" C. 3	Super Lithium "Filtrate" Grease	"Ambroline" L.H.T. Grease	Duckham's L.B. 10 Grease or H.B.B. Grease	"Castrol" Heavy	Home—"Esso" Grease Export—Hubs : "Esso" Bearing Grease Fan : "Esso" Chassis Grease
<b>D</b> STEERING CONNECTIONS, KING-PINS, PROPELLER SHAFT, CLEVIS PINS AND LEVER FULCRUMS								
All conditions	Mobilgrease No. 2 or 4	"Shell" Retinax A	"Energol" C. 1	Super Lithium "Filtrate" Grease	"Ambroline" L.H.T. Grease	Duckham's L.B. 10 Grease or H.P.G. Grease	"Castrol" Medium	Home—"Esso" Pressure Gun Grease Export—"Esso" Chassis Grease
<b>E</b> CABLES AND VITAL CONTROL JOINTS								
All conditions	Mobilgrease No. 2 or 4	"Shell" Retinax A	"Energol" C. 1	Super Lithium "Filtrate" Grease	"Ambroline" L.H.T. Grease	Duckham's L.B. 10 Grease or "Keenol" K.G. 16 Grease	"Castrol" Brake Cable Grease	Home—"Esso" Pressure Gun Grease Export—"Esso" Chassis Grease
<b>F</b> UTILITY LUBRICANT, S.U. CARBURETTER DASHPOT, OILCAN POINTS, ETC.								
All conditions	Mobiloil "Arctic"	"Shell" X-100 20/20 W	"Energol" S.A.E. 20 W	Zero "Filtrate" 20	"Sternol" W.W. 20	Duckham's N.O.L. "Twenty"	"Castrolite"	"Essolube" 20